

SERVICE HANDBOOK FOR STANDARD RESIDENTIAL GAS WATER HEATERS

(NON POWER VENTED MODELS)



Printed in the USA 0604
\$15.00

Part Number STC-080

This service handbook addresses service issues associated with Standard Residential Gas Water Heaters. Includes C-3 Flammable Vapor Technology.

RESIDENTIAL GAS, NON POWER VENTED, WATER HEATER SERVICE HANDBOOK

TABLE OF CONTENTS

	Page		Page
Introduction		Service	10
Terms.....	1	Procedures and Conditions	11
Tools	2	Multiple Heater Piping.....	14
		Exhaust Venting Notes	15
Residential Gas Water Heaters		Flammable Vapor Ignition Design	15
Guidelines.....	3	Lint, Dust & Oil Screen.....	16
Installation.....	5	Flame Arrestor.....	17
		Thermal Cut Off Switch.....	18
Operations and Servicing		Pilot Burner Assembly.....	19
Construction.....	6	Sealed Combustion Chamber.....	20
Control	6	Piezo Igniter.....	21
Burner	7	Technical Bulletins	26
Normal Operations	7		
Temperature	8		
Gas	8		
Water Flow.....	9		

RESIDENTIAL GAS SERVICE HANDBOOK INTRODUCTION

This service handbook is designed to aid in servicing and troubleshooting State Non Power Vented, Residential Gas water heaters in the field. No duplication or reproduction of this book may be made without the express written authorization of the manufacturer.

The following text and illustrations will provide you with a step-by-step procedure to verify proper installation, operation, and troubleshooting procedures. Additional quick reference data is included to assist you in servicing this product.

The information contained in this handbook is designed to answer commonly faced situations encountered in the operation of the Residential Gas, non power vented, product line and is not meant to be all-inclusive. If you are experiencing a problem not covered in this handbook, please contact the State Water Heater Call Center at 1-800-365-0024 or your local State Water Heater Service Representative for further assistance. Additional information is also available on the web site www.Statewaterheaters.com. This handbook contains supplemental information to the Residential Gas installation instructional manual supplied with the water heater.

Qualifications

This handbook is intended for use by licensed plumbing professionals and reference should be made to the instructional manual accompanying the product.

RESIDENTIAL GAS, NON POWER VENTED, WATER HEATER SERVICE HANDBOOK

Tools Required:

- Phillips head screw driver
- 3/8, 7/16, 3/4 inch open end wrenches
- 3/16 inch Allen wrench
- 11/16 inch – 6 point – socket – for anode removal
- set of marked drill bits
- electrical multimeter
- gas pressure gauge or monometer
- water pressure gauge
- thermometer
- tubing cutter if pilot tube is to be replaced
- hose – to drain tank
- container – to measure gallons per minute flow

MISCELLANEOUS INFORMATION

Draw efficiency is the quantity of hot water available to the consumer before the outlet water temperature decreases 25 degrees F. A 40 gallon water heater will typically provide 70% (28 gallons) of this “usable” hot water. The burner is allowed to operate during this test. Incoming, cold water mixes the remaining stored water below this 25 degree limitation.

Energy Factor is an indicator of the combined thermal efficiency and standby efficiency of a water heater. The higher the energy factor, the more efficient the water heater will be.

Recovery rate is the amount of water that is heated to a set temperature, per hour. An example might be that a water heater has a recovery rate of 30 gallons of water per hour at 80 degree F. (Fahrenheit) temperature rise.

“R” Value is a measure of the resistance of a substance to heat flow.

Thermal efficiency is approximately the amount of generated BTU (British Thermal Units), which enters the water. A percentage of the total BTU passes out through the vent piping.

Temperature rise is the increase in the temperature from its coldest “inlet” water temperature to the desired hot (outlet) setting. Typically this is assumed to be 40 degrees entering water; 120 degrees desired stored water or 80 degrees “temperature rise.”

Standby efficiency – the water heater’s ability to contain heat in the tank. A minimum of tank water heat loss per hour is desired.

Sample: $\frac{\text{temperature change}}{\text{“R” value}} = \text{Btu/h loss/ square foot of tank surface}$

Water cannot (for all practical purposes) be compressed.

Water expands when it is heated.

RESIDENTIAL GAS, NON POWER VENTED, WATER HEATER SERVICE HANDBOOK

Water Hammer – is a concussion of moving water against the sides of a containing pipe or vessel on a sudden stoppage of flow.

EX: 1/2 "copper pipe, 5GPM flow (7.2ft/sec.) – stop. Pressure rise of approximately 412 PSI.

3/4" copper pipe, 5GPM flow (3.3ft/sec) – stop. Pressure rise of approximately 188 PSI

Minerals and gases will separate from water as temperature increases.

Formulas:

Btu (British Thermal Unit) is the heat required to raise 1 pound of water 1°F

$$1 \text{ BTU} = 252 \text{ cal} = 0.252 \text{ kcal}$$

$$1 \text{ cal} = 4.187 \text{ Joules}$$

$$\text{BTU} \times 1.055 = \text{Kilo Joules}$$

$$\text{BTU divided by } 3,413 = \text{Kilowatts}$$

To convert from Fahrenheit to Centigrade: ($^{\circ}\text{F} - 32$) times $5/9$, or $.556$, equals degrees C.

One gallon of (120°F , 49°C) water weighs approximately 8.25 pounds.

$$\text{Pounds} \times .45359 = \text{Kilogram}$$

$$\text{Gallons} \times 3.7854 = \text{Liters}$$

% of Hot = (Mixed Temp. – Cold) divided by (Hot Temp. – Cold)

% Thermal Efficiency = (GPH X 8.25 X Temp. Rise X 1.0) divided by BTU/H Input

Btu Output = GPH X 8.25 X Temp. Rise X 1.0

GPH = (BTU/H Input X % Eff.) divided by (Temp. Rise X 8.25)

One cubic foot of Natural Gas contains about 1000 BTU of heat.

One "therm" is equal to 100,000 BTU

One cubic foot of Propane Gas contains about 2500 BTU of heat.

One gallon of Propane gas contains about 91,250 BTU of heat.

One pound of Propane gas contains about 21,600 BTU of heat.

One pound of **gas pressure** is equal to 27.7 inches water column pressure

$$\text{Inches of Water Column} \times .036091 = \text{PSI}$$

$$\text{Inches of Water Column} \times .073483 = \text{Inches of Mercury (Hg.)}$$

RESIDENTIAL GAS, NON POWER VENTED, WATER HEATER SERVICE HANDBOOK

Centimeters = Inches X 2.54

MM (millimeters) = Inches X 25.4

Meters = Inches X .0254

Doubling the diameter of a pipe will increase its flow capacity (approximately) 5.3 times.

CONSTRUCTION:

Tank is constructed of steel.

The inside of the tank is constructed of a **glass lining** bonded to the steel. This prevents water to metal contact and rusting of the tank.

An **anode rod** will be installed within the tank. The hex-head plug end of the anode is visible on the top of the water heater. This metal rod offers secondary protection of the tank against corrosion where the application of glass is not possible (threaded tank openings). These areas will have small areas of water to metal contact.

All water heaters will contain at least **one thermostat** (to operate the heater) and **one high limit** (to prevent water temperatures approaching the "steam" level).

RESIDENTIAL GAS, NON POWER VENTED, WATER HEATER SERVICE HANDBOOK

INSTALLATION OF RESIDENTIAL GAS WATER HEATER

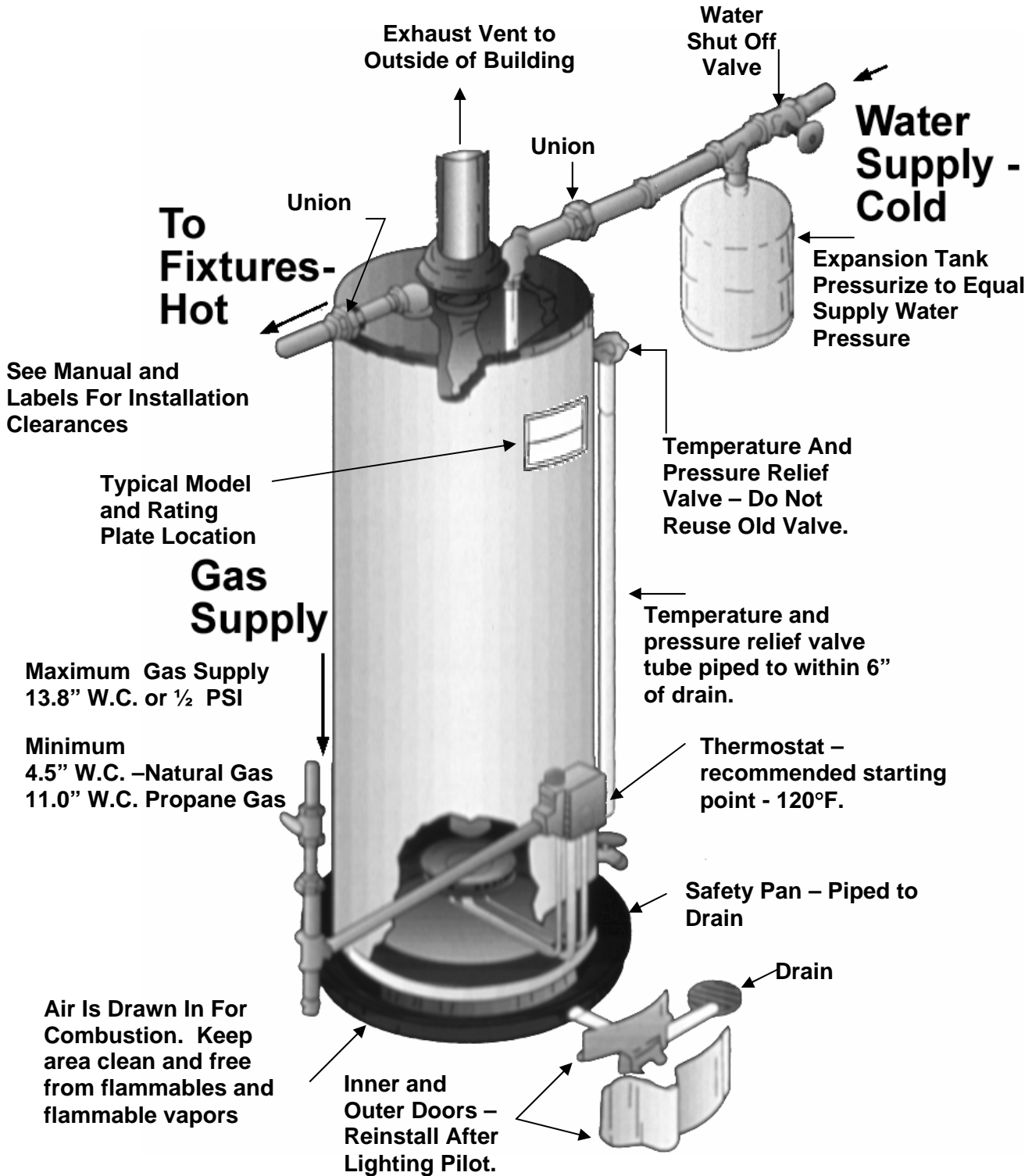

Installation Must Follow Local Codes and Instruction Manual Guidelines

RESIDENTIAL GAS, NON POWER VENTED, WATER HEATER SERVICE HANDBOOK

RESIDENTIAL GAS WATER HEATER SERVICE

This portion of this manual applies to the Operations and Servicing of Residential Gas, Tank Type, Water Heaters, which are vented atmospherically and use a thermocouple as their electrical source.

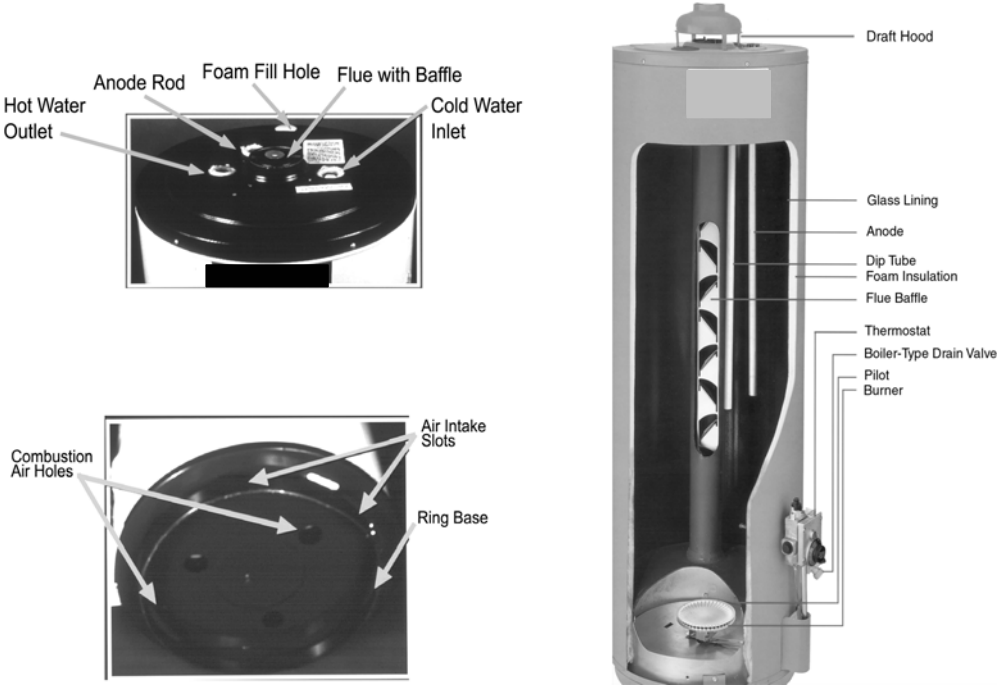

Control: There is one control on this style of water heater. The control has a main gas regulator, pilot gas regulator, on-off-pilot knob, controls water temperature, has a temperature adjustment knob, and a high water temperature limit safety.

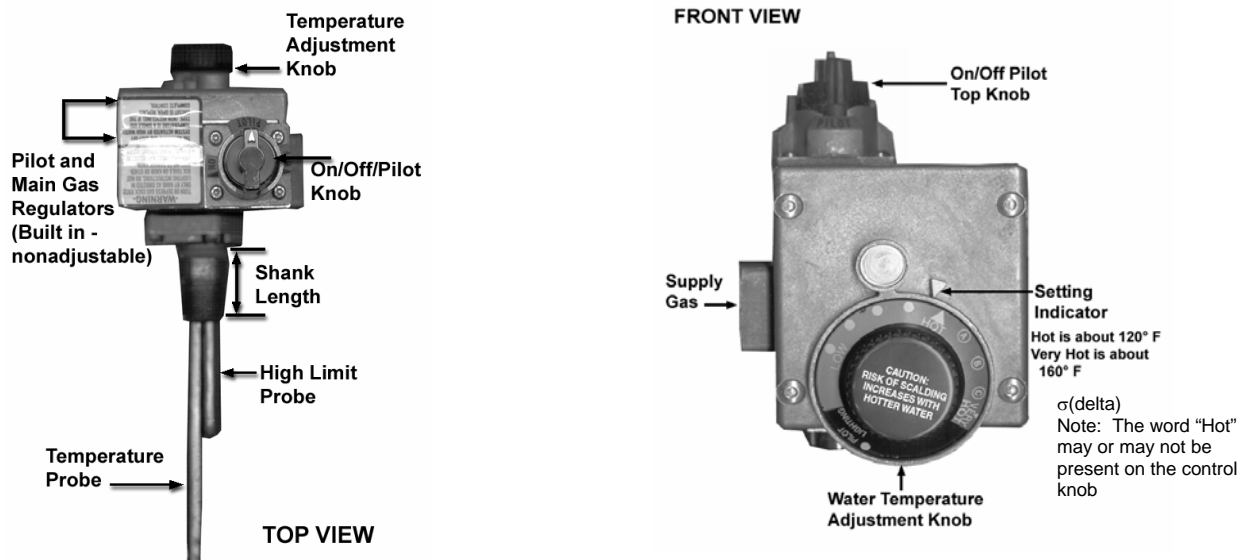

RESIDENTIAL GAS, NON POWER VENTED, WATER HEATER SERVICE HANDBOOK

Residential Gas – continued

Burner: The burner assembly consists of the main burner, main burner orifice, main burner gas supply tube, pilot burner, pilot burner orifice, pilot burner gas supply tube and thermocouple.

The pilot burner remains on once it is manually lit. When incoming cold water activates the thermostat, gas flows to the main burner. The pilot flame ignites this gas. The main flame burns until the tank reaches set temperature then the thermostat interrupts this main gas flow.

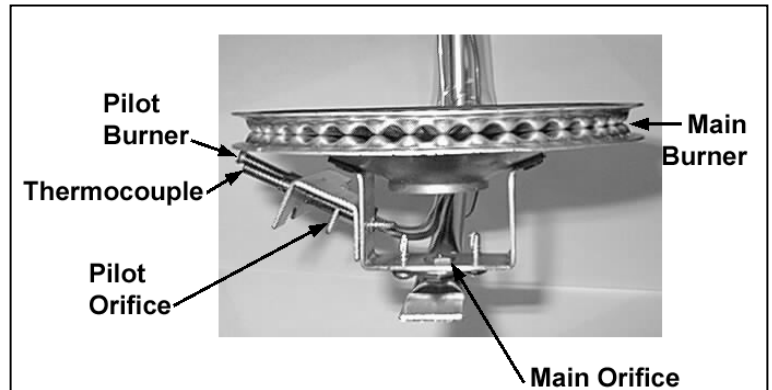
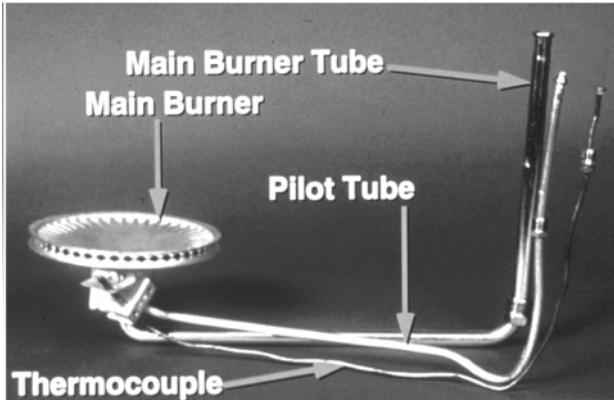

AFTER HAVING CONFIRMED THAT THE WATER HEATER HAS BEEN INSTALLED PER THE INSTALLATION MANUAL INSTRUCTIONS:

Normal Operation

Electrical: The Pilot Flame heats the end of a thermocouple. As the thermocouple is heated, it generates a small (cannot be detected without an electrical meter) electrical current to the bottom of the control valve. This current powers the electromagnet and holds open the safety valve as long as the pilot flame is heating the thermocouple. **DANGER!** If the pilot is extinguished, it can take up to 180 seconds for the thermocouple to cool sufficiently to close the safety valve.

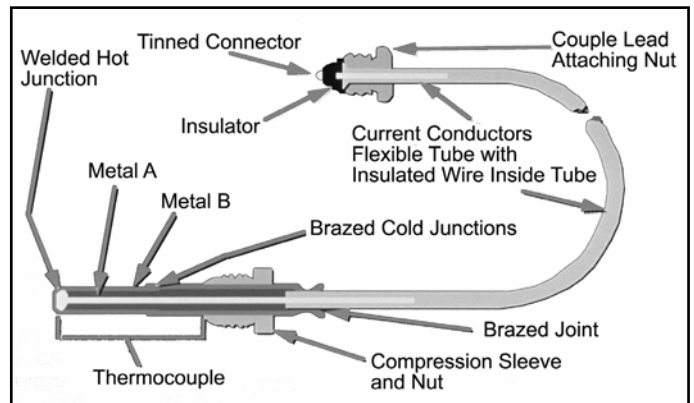
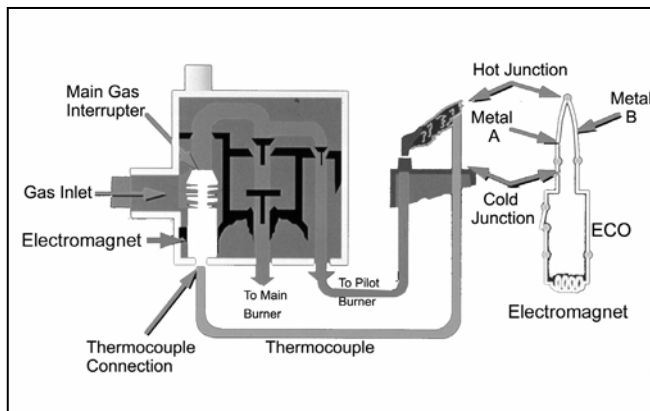

See also C3 technology product information beginning on page 15 .

RESIDENTIAL GAS, NON POWER VENTED, WATER HEATER SERVICE HANDBOOK

Residential Gas – continued

Temperature: Two metal probes mounted onto the back of the control are immersed inside the tank water. One probe (the shorter) acts as a temperature high limit. If water gets excessively hot, a sensor within the probe opens, interrupts the small electrical current to the gas valve, and gas flow through the control is interrupted. If this safety sensor opens, the entire control must be replaced.

The longer probe contains a metal rod that expands and contracts as water temperature around the probe cools and heats. As the rod expands, it pushes against a lever actuated gas valve. If the regulator is pushed sufficiently, gas flow is interrupted to the main burner. Adjusting the temperature dial changes the distance the rod must expand or contract to open or close the gas valve.

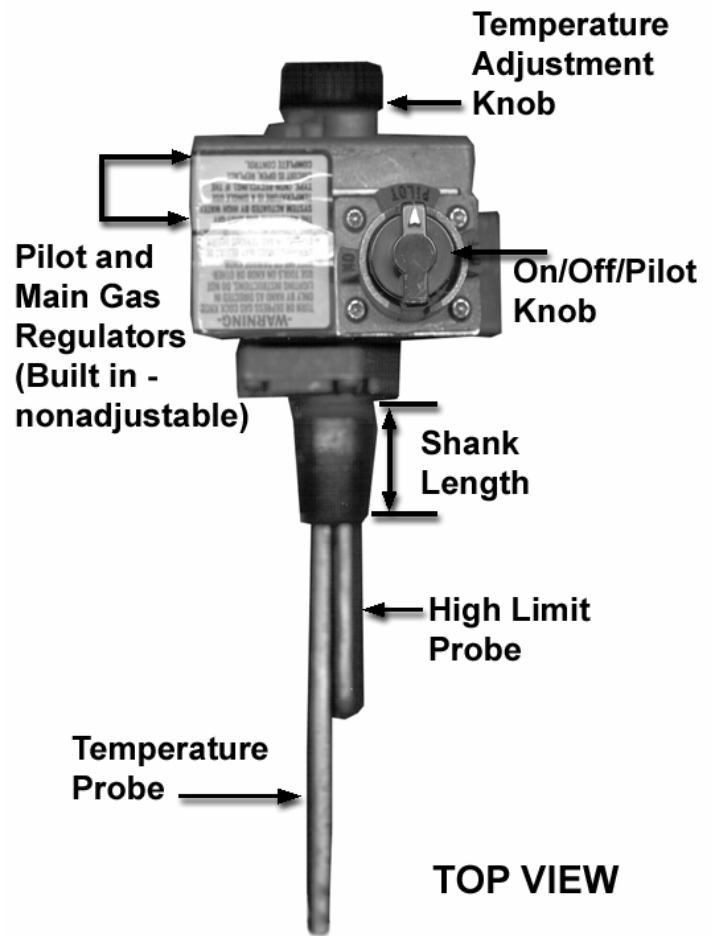

Gas: When you prepare to light the pilot, you are instructed to turn the top knob to the pilot position and depress the knob. When the knob is depressed gas will flow to the pilot burner only. You then have to (manually) ignite this pilot gas. When the pilot is lit, the flame must heat the thermocouple until it generates sufficient electricity to the gas valve to allow you to release the knob while gas continues to flow to the pilot. When the top knob is turned to the “ON” position, gas is also available to the main burner if the thermostat calls for heat.

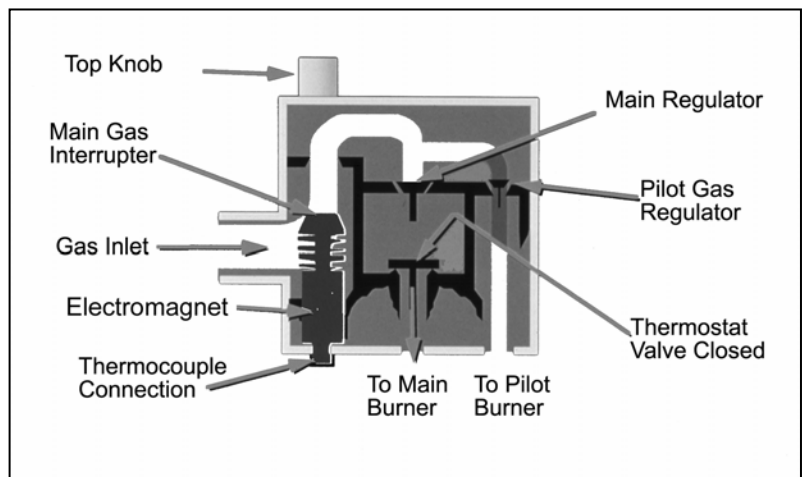

RESIDENTIAL GAS, NON POWER VENTED, WATER HEATER SERVICE HANDBOOK

Residential Gas - continued

Water Flow: When a hot water faucet is opened, water pressure from the well tank or street main forces cold water into the water heater. This pushes hot water out of the tank.

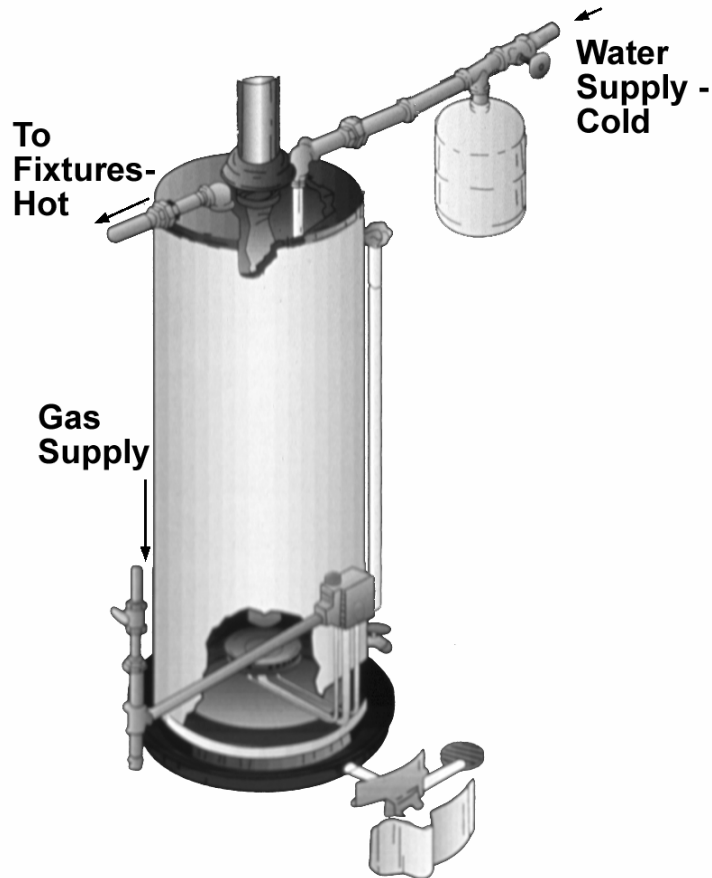

Operation: A residential water heater is not a precise operating appliance. Because the water heater relies on the expansion and contraction of a metal rod, when the thermostat dial is set at an indicated setting (“▲” is recommended as a starting setting. This is approximately 120 degrees F.) The heater may shut off at 110 to 130° F. The heater will consistently shut off at this same temperature. For this same reason, water temperature may drop 15 - 25° F, around the temperature probe, before the main burner is activated. Keep in mind that hot water in the upper part of the tank will probably be very near the “shut off” temperature of the control while incoming cold water drops the water temperature around the thermostat probe. Also, short repeating heating cycles caused by small hot water uses can cause temperatures at the point of use to exceed the thermostat setting by up to 30° F.

Setting	Approximate Temperature (°F)	Time To Produce 2 nd & 3 rd Degree Burns on Adult Skin
Hot (▲)	120° ± 10°	5 Minutes
A	130° ± 10°	30 Seconds
B	140° ± 10°	5 Seconds
C	150° ± 10°	1.5 Seconds
Very Hot	160° ± 10°	Under 1 Second

RESIDENTIAL GAS, NON POWER VENTED, WATER HEATER SERVICE HANDBOOK

Residential Gas - continued

Service:

Air: A gas burning appliance requires the oxygen contained in 12.5 cubic feet of air (at sea level) for every 1000 BTU of heat that is generated. If your water heater has a BTU per hour input of 40,000 BTU then a minimum of 500 (40 times 12.5) cubic feet of clean air must be available. This oxygen will mix with the gas for a clean, blue flame in the burner chamber and provide dilution air for flue products.

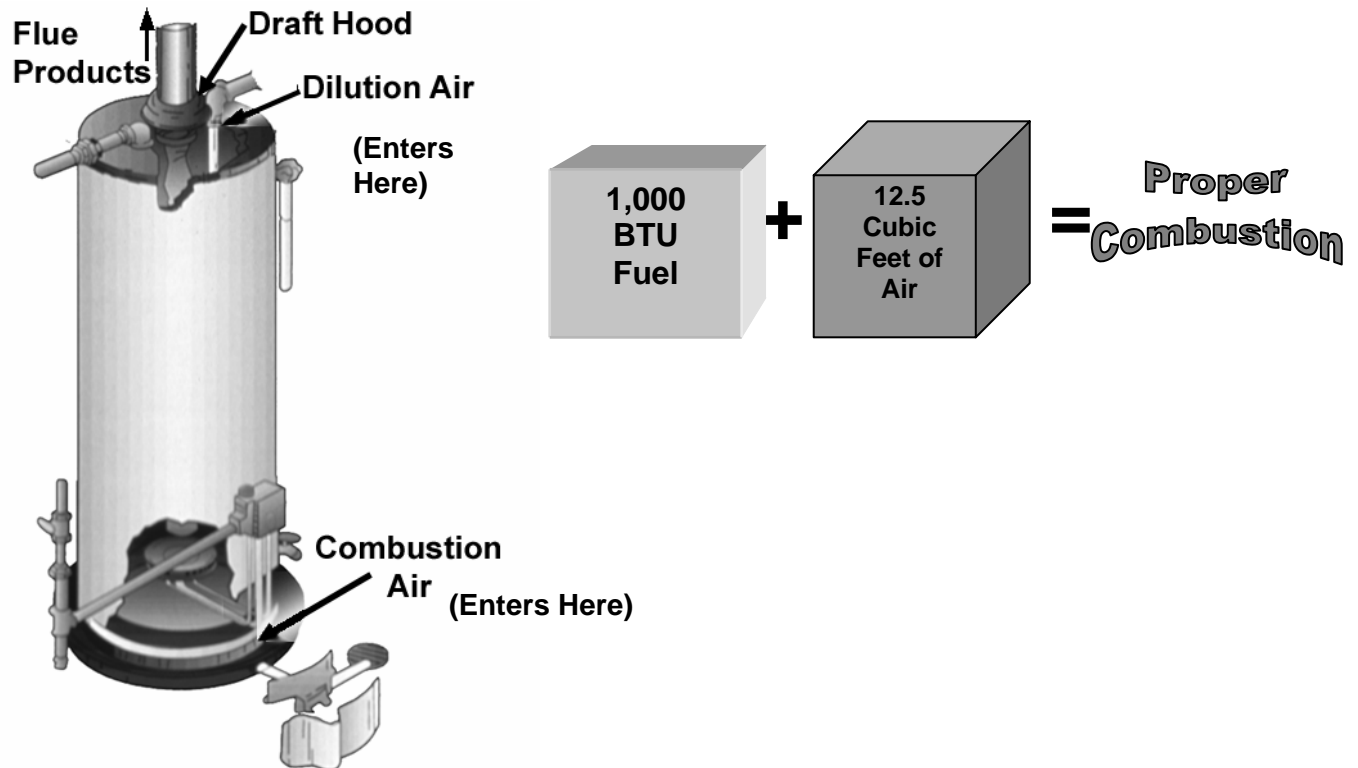

Do not forget that your gas (or oil) furnace and gas clothes dryer also require a like amount of air.

When calculating air supply provisions, also consider the presence of whole house exhaust fans or other exhaust fans competing for the same air supply.

Air must be allowed to enter the heater chamber from the base of the heater and also enter the flue vent from below the draft hood. Do not block these areas with insulation blankets or obstructions lying around the base of the heater.

Lack of Oxygen: If a sufficient supply of oxygen (air) is not available for combustion and dilution, the result will be:

- Pilot outage
- Yellow burner flame
- Sooting water heater

RESIDENTIAL GAS, NON POWER VENTED, WATER HEATER SERVICE HANDBOOK

- Possible carbon monoxide
- Smell of burnt gas in the room

Residential Gas – continued

The instruction manual gives guidelines under “Air Requirements” and “Unconfined “ or “Confined Space” sections. If you want to test for a lack of air:

1. Turn on every appliance and fan that exhausts air from the utility room and/or house. Make sure all windows and doors are closed, as well as chimney dampers.
2. Open a hot water faucet so that the main burner will ignite
3. Remove the outer door of the water heater – not the inner door
4. Monitor the flame characteristics for several minutes

If the flame begins to “yellow” open a door or window, to the outdoors, to see if additional air corrects this back to blue. If it does, the room needs more air supply. Perform draft test at draft hood of water heater with match or smoke source to verify.

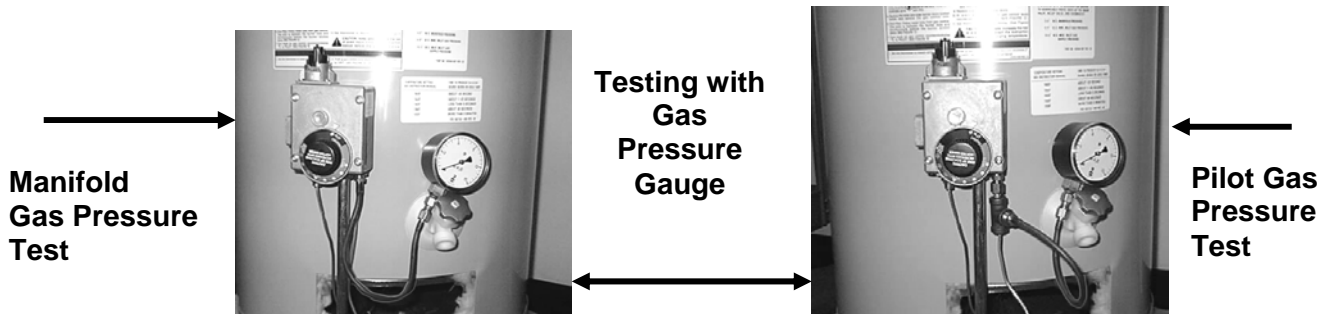

Gas pressure checks are done with flowing gas.

Supply gas pressure checks are taken ahead of the gas control and as close to the heater as possible.

Pilot gas pressure checks are taken by using fitting adapters to tap into the pilot gas tubing.

Manifold (main burner) gas pressure is measured using the Allen wrench tap on the bottom of the control valve.

Desired gas pressures will be noted on the gas valve label.

If then
supply gas pressure is under desired pressure setting	<ul style="list-style-type: none"> • increase supply gas pressure regulator setting and, • increase supply gas piping size.
supply gas pressure is over desired pressure	<ul style="list-style-type: none"> • add gas pressure regulator. • reduce setting on existing regulator.
pilot gas pressure is more than +/- .3 inch W.C. from desired	replace the control valve.
manifold gas pressure is more than +/- .3 inch W.C. from desired	replace the control valve.

Additional considerations when pilot or main burner flames are too large or too small:

- Incorrect orifice
- Dirt in orifice or gas supply tubing

RESIDENTIAL GAS, NON POWER VENTED, WATER HEATER SERVICE HANDBOOK

Residential Gas - continued

Sooting causes:

If then
the burner is clean but the chamber and/or flue are sooted	check for lack of supply air.
the main burner, chamber and flue are sooted	check the following: <ul style="list-style-type: none"> • incorrect orifice • excessive gas pressure • loose main burner • cross threaded orifice • gas control valve gas seepage • loose gas connection in burner assembly.

Electrical Testing

This type of water heater has its own electrical generating system.

When two dissimilar metals are joined together and this joint is heated, a small, electrical current will be produced. A thermocouple uses this science.

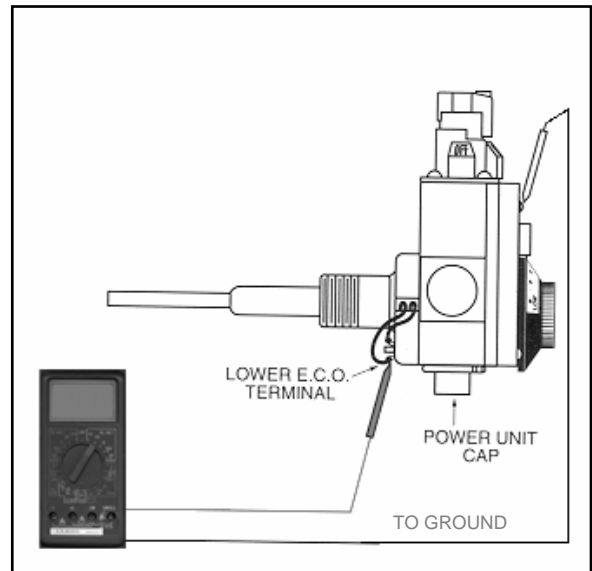

Thermocouple output test

Procedures/Conditions:

Meter set for DC millivolt testing

Test from lower ECO (emergency cut off or energy cut off) solder joint to ground.

Note: If pilot will not stay lit, manually hold the top knob down in the pilot position. This allows gas to flow to the pilot. Light the pilot and continue to hold this knob down while conducting the test.

If then
reading test of at least 13 mV is not present	<ul style="list-style-type: none"> • check that flame contacts end of thermocouple • replace thermocouple.
reading test of at least 13 mV is present	continue to next test.

RESIDENTIAL GAS, NON POWER VENTED, WATER HEATER SERVICE HANDBOOK

Residential Gas - continued Electrical Testing– continued

Millivolt dropout test through copper magnet winding and ECO (Emergency Cut Off)

Procedure: Move meter probe to upper ECO solder joint and ground

If then
reading of at least 10 mV is not present	replace the control valve.
reading of more than 10 mV is present but, gas to the pilot shuts off each time knob is released	replace the control valve.

Safety drop out test –

The safety shutoff should interrupt gas through the valve when mV current drops to 1-3 mV.

Procedures:

Meter still connected to upper ECO solder joint and ground.

Turn Top Knob to “off” position

Millivolt output will decrease as thermocouple cools

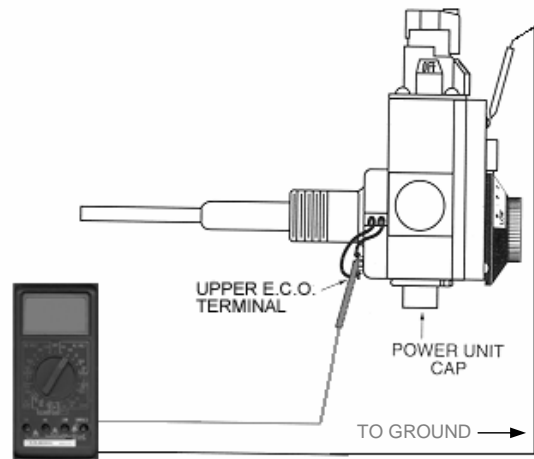

If...	... then
internal safety does not activate between 1 and 3 mV (you will hear a “click” inside the valve)	replace the control valve.
*internal safety does activate between 1 and 3 mV	valve is within tolerance and will interrupt gas flow if pilot loses heat or ECO opens.

*Note: A “click” sound should be heard from the valve as the main gas interrupter snaps up to the “closed” position.

Condensation

Flue gas products contain moisture. If these flue gas products are cooled to their “dew point”, they become visible moisture – condensation.

Flue gas may become cooled by:

- Cold supply air temperatures
- Cool surfaces – generally, if tank water temperatures drop below 110°F, the flue pipe surface and/or bottom tank head will be cool enough to cause condensation.
- Increased combustion efficiency – higher thermal efficiency means that an increased amount of heat is transferring from the flue gas into the water. If you transfer (approximately) 87.5%, or more, the moisture in the flue gas will condense.

RESIDENTIAL GAS, NON POWER VENTED, WATER HEATER SERVICE HANDBOOK

Residential Gas – continued

Condensation is a mild acid – it will corrode steel

Condensation is usually noted when:

- water dripping is heard (only) while the main burner is on,
- there is “water” around the heater just after the heater has been operating,
- there are small, black or red granules on the main burner or top of the heater or
- corroded jacket or vent piping is noted.

If then
any of the above conditions exist	<ul style="list-style-type: none"> • raise the supply air temperature or • increase stored water temperature or • increase the size of the tank <p>You would not wish to lower combustion efficiency – this would waste gas. Use materials (stainless steel, PVC etc.) that will not be affected by the condensation</p>

Suggested Multiple Heater Water Piping Required For Proper Operation of Top Connect Models

Installed in accordance with local codes.

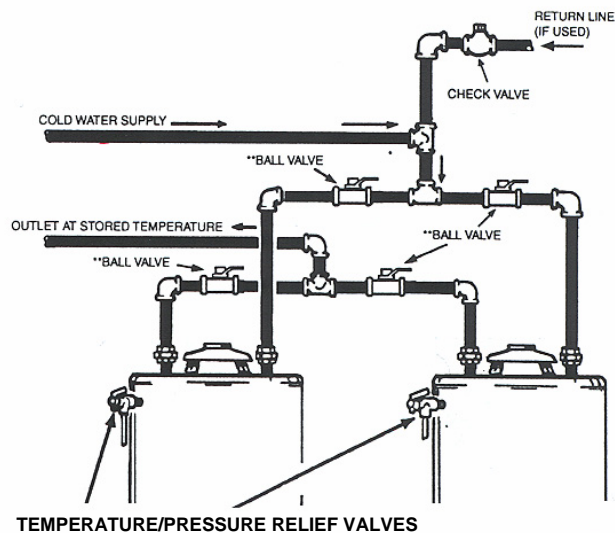
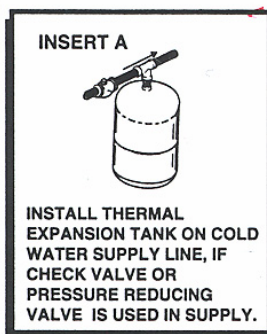

RESIDENTIAL GAS, NON POWER VENTED, WATER HEATER SERVICE HANDBOOK

Residential Gas – continued

Exhaust Venting Notes

Follow current National Fuel Gas Code requirements for proper installation.

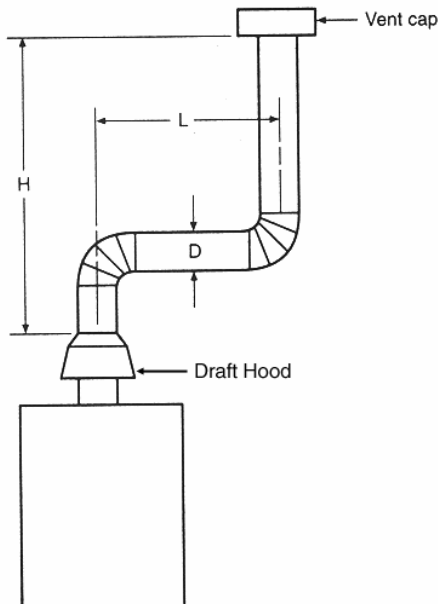

“D” – Typically, same or larger diameter as Draft Hood outlet

“L” – Horizontal piping slopes upward ¼” per foot from heater to chimney or vertical vent
Length of horizontal not more than 75% of “H”

“H” – Not less than 5 feet

Maximize vertical distance to first elbow

FLAMMABLE VAPOR IGNITION RESISTANT (FVIR) DESIGN

This section will address the changes brought about by the introduction of FVIR compliant products. Other than items mentioned here, the construction, installation, and service will remain the same as discussed in the primary handbook.

The FVIR acronym stands for "Flammable Vapor Ignition Resistant." The State products are based on "Corderite Combustion Containment" known as "C3 Technology™". The C3 Technology design features a sealed (from non designated air intake openings) combustion chamber and a "flame arrestor" component.

This class of residential gas water heaters meet the new ANSI standards and testing protocols (ANSI Z21.10.1) established to deal with the accidental or unintended ignition of flammable vapors, such as those emitted by gasoline. Virtually all gas-fired, atmospherically vented, residential water heaters manufactured in the United States with BTU ratings of 75,000 or less are required to meet this new ANSI standard effective July 1,2003. The current implementation schedule for C3 TECHNOLOGY compliant residential gas-fired products is shown in the following table. These dates are subject to change.

RESIDENTIAL GAS, NON POWER VENTED, WATER HEATER SERVICE HANDBOOK

IMPLEMENTATION CATEGORY	ANTICIPATED INTRODUCTION	CLASS OF PRODUCTS INCLUDED IN THIS CATEGORY
Phase I	July 1, 2003 (July 1, 2004* Can.)	30, 40, and 50 gallon atmospheric vented. (Manufactured housing models are excluded.)
Phase II	January 1, 2005*	30, 40, and 50 gallon power-vented models. (Manufactured housing models are excluded.)
Phase III	July 1, 2005*	All other gas-fired models with inputs of 75,000 BTU or less.

* Subject to change. This supplement addresses the July 1, 2003 compliant products.

In addition to the standard water heater design discussed in the main service handbook, the C3 Technology design also includes:

- A LDO (Lint Dust and Oil) screen over the combustion air intake
- A Flame Arrestor
- A combustion chamber Thermal Cut Off (TCO) limit

An additional tool for these products might be a vacuum cleaner with both blowing and vacuuming capabilities. Also include the long, narrow crevice accessory.

LDO SCREEN (LINT, DUST, OIL) SCREEN(S)

An easy to clean screen designed to minimize lint, dust and oil based contaminants from being drawn into the “Flame Arrestor” along with make up – combustion - air. There may be one or two of these screens. The LDO screen must be installed with the arrows on the right and left side facing up to function properly. (The arrows are located on two mounting tabs on each side of the screen).

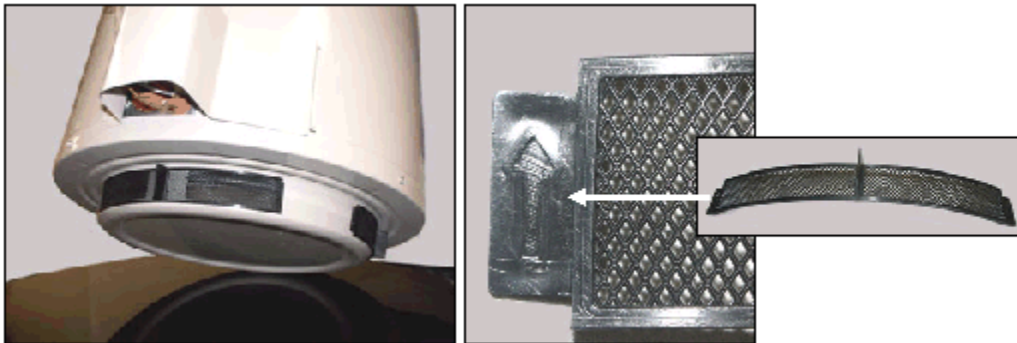

Service:

Inspect the LDO screen(s) regularly. Clean or wash as necessary.

Pulling the tab located in the middle of the screen will remove the screen. Reinstall the clean screen by inserting the end tabs into the jack with the arrows pointing up.

Possible Service issues associated with a blocked screen:

- Poor combustion – yellow flame, possible sooting
- Pilot outage resulting from a lack of oxygen
- Pilot outage resulting from to increased combustion chamber temperature below the main burner. This may open the automatic reset, thermal cut off switch (TCO).

RESIDENTIAL GAS, NON POWER VENTED, WATER HEATER SERVICE HANDBOOK

FLAME ARRESTOR

Made from Corderite, a fireproof ceramic material, the flame arrestor is built into the base of the water heater. Combustion air is drawn in through the LDO screen (s). After entering the bottom area of the water heater, this air passes up through the small ports of the flame arrestor and into the combustion chamber.

In the event flammable vapors are introduced accidentally into the combustion chamber, the flame arrestor is designed so any flames burn off the top surface of the arrestor and cannot escape down through the arrestor. The arrestor works somewhat like a check valve.

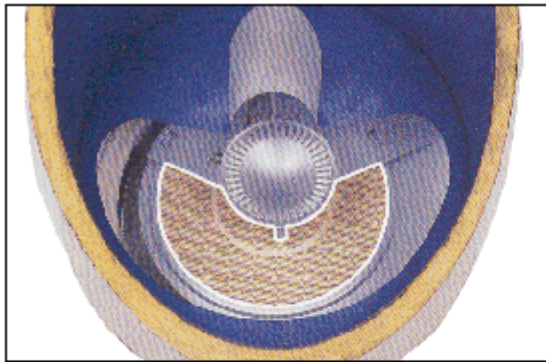

Top cutaway view of flame arrestor.



Bottom view of flame arrestor.

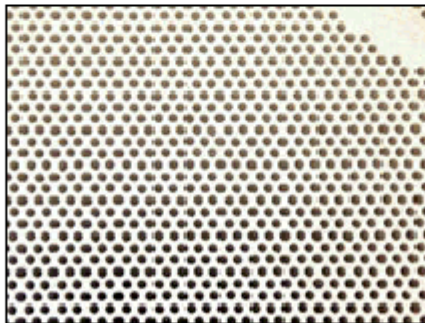

Close up view of Corderite flame arrestor material.

Service:

Inspect the bottom ports of the flame arrestor by removing the LDO screen (s) and using a mirror and flashlight. Clean the ports if necessary by vacuuming the bottom of the arrestor.

Inspect the top of the flame arrestor by removing the inner door and burner assembly. Lift the heat shield located on the bottom of the chamber. Inspect with the mirror and flashlight. Vacuum or blow down any blocking material. If you blow down through the ports, be certain to also vacuum below the arrestor.

RESIDENTIAL GAS, NON POWER VENTED, WATER HEATER SERVICE HANDBOOK

If there has been a flammable vapor ignition, a qualified service agent needs to inspect the arrestor for cracks. The arrestor is not a replaceable part – the heater would need to be replaced.

Possible service issues associated with the flame arrestor.

- Poor combustion – yellow flame, sooting, possible carbon monoxide production.
- Pilot outage due to lack of oxygen. Continued pilot outage or finding that the LDO screen(s) is heavily blocked would warrant inspection of the flame arrestor.
- Pilot outage due to increased combustion chamber temperatures below the main burner. This may open the automatic reset, thermal cut off switch (TCO).
- The flame arrestor having contained a flammable vapor ignition. The TCO will open and the chamber and arrestor should be inspected by a qualified service agent.

COMBUSTION CHAMBER TEMPERATURE SENSOR

The C3 Technology water heaters will come equipped with a thermal cutoff (TCO) device that is integral with the thermocouple. Temperature cutoff points range from 160°C to 200°C depending on model. The TCO is an automatic reset thermal switch. When activated it will open the thermocouple circuit and shut off the main and pilot burner gas flow. The pilot would have to be relit after the TCO has had sufficient time to cool down (sensor is below 120 degrees F).

In addition to printing the temperature setting on the TCO, a label located near the gas valve attachment end of the thermocouple notes the temperature setting of the TCO.

The TCO performs two primary functions:

- In the event of flammable vapor ignition inside the combustion chamber, it senses the corresponding increase in temperature and shuts off gas flow to the main and pilot burners.
- If excessive temperatures inside the combustion chamber indicate poor combustion due to a clogged LDO screen or inadequate air for combustion, the TCO will shut off gas flow to the main and pilot burners.



190°C TCO

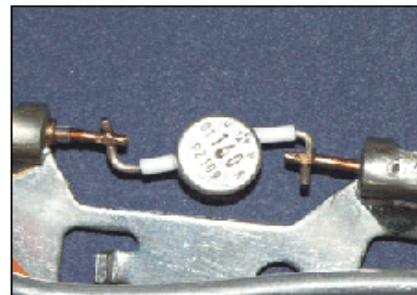

160°C TCO

RESIDENTIAL GAS, NON POWER VENTED, WATER HEATER SERVICE HANDBOOK

SERVICE:

There is no routine service associated with the TCO. The standard thermocouple millivolt output checks described in this service handbook still apply. Millivolt readings indicate that the TCO is closed. An open TCO (within a cool chamber) would indicate that the assembly must be replaced.

The TCO is an integral part of the thermocouple and not replaceable as a separate item. A pilot burner assembly must be reinstalled. On repeated calls of no hot water or pilot outage, a clogged/dirty LDO screen might be the cause and should be checked. Keep in mind this TCO will shut off the pilot and main burner when activated.

With the different cutoff temperature set-points of TCO devices for different model water heaters, it is important that the correct part is used when replacement of the pilot burner assembly is necessary.

Possible service issues associated with the Thermal Cut Off switch being opened:

- Pilot outage due to increased combustion chamber temperatures below the main burner. This may open the automatic reset, thermal cut off switch (TCO).
- The flame arrestor having contained a flammable vapor ignition. The TCO will open and the chamber and arrestor should be inspected by a qualified service agent.

ONE PIECE PILOT BURNER ASSEMBLY

C3 Technology models feature a "one piece" pilot burner assembly. There are five main components that make up this pilot assembly:

1. Thermocouple with integral Thermal Cut Off switch (TCO).
2. Pilot burner w/orifice and tubing
3. Piezo igniter cable
4. Pilot assembly seal/grommet (orange).
5. An inner door gasket (white) will also be included.

RESIDENTIAL GAS, NON POWER VENTED, WATER HEATER SERVICE HANDBOOK

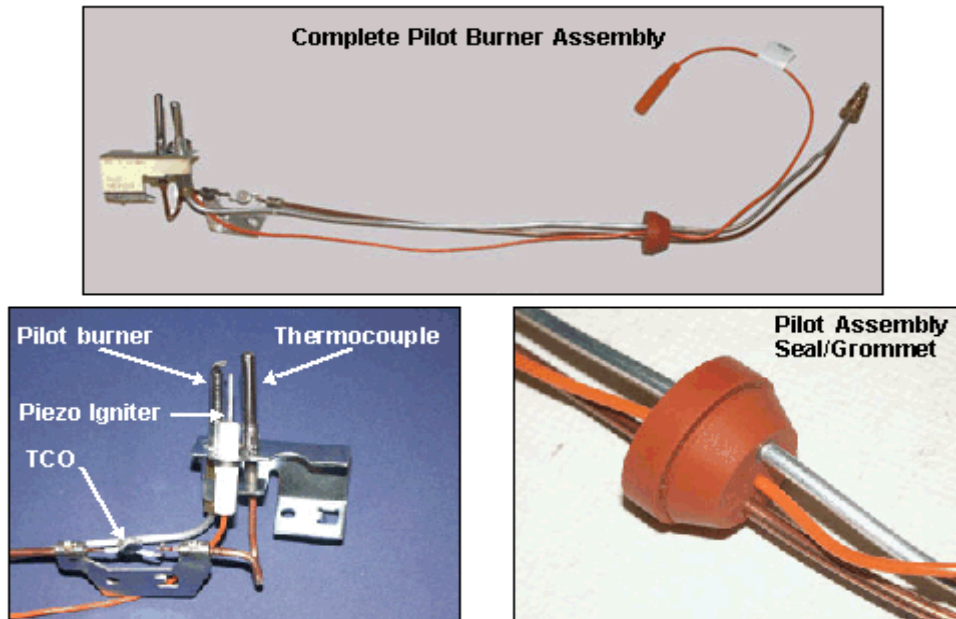

To replace a pilot assembly:

1. Turn off the gas supply
2. Disconnect the piezo cable from the piezo button (connection near gas control valve).
3. Disconnect the pilot tubing, thermocouple and main burner tube from the bottom of the gas control valve.
4. Remove (2) 3/8 inch nuts securing the inner door.
5. Remove the entire burner assembly.
6. Remove screw securing pilot burner assembly to pilot mounting bracket.
7. Remove pilot assembly - with orange gasket – from the back side of the inner door.
8. Reinsert new pilot assembly into back side of inner door. Wetting the orange gasket may help in securing the gasket into place.
9. Reattach the new pilot assembly to the pilot mounting bracket.
10. Inspect/replace the white, inner door gasket before making the connections to the bottom of the gas control valve.
11. Reattach the piezo cable to the piezo button.
12. Remount the inner door.
13. Follow the pilot lighting instructions including gas and gasket leak checks.
14. Install the outer door.

SEALED COMBUSTION CHAMBER

The combustion chamber is factory sealed around the flame arrestor and the upper and lower perimeter of the chamber. Access for service is provided through an inner door as with current product. However, this inner door is now sealed with; a door gasket, a pilot assembly grommet type seal, and a main burner tube boot/sleeve type seal.

RESIDENTIAL GAS, NON POWER VENTED, WATER HEATER SERVICE HANDBOOK

The three seals on the inner door should be checked every time any service is performed. The sight glass should be checked to insure it is not damaged or missing. The pilot tube and thermocouple routing should be straight (not bent at an angle close to the surface of the seal) as it passes through the pilot assembly seal.

A "five point inner door seal inspection" is outlined below:

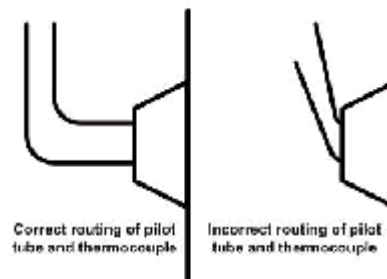
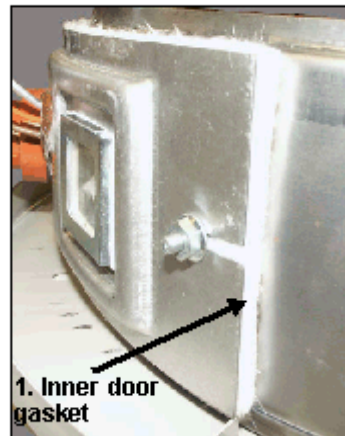
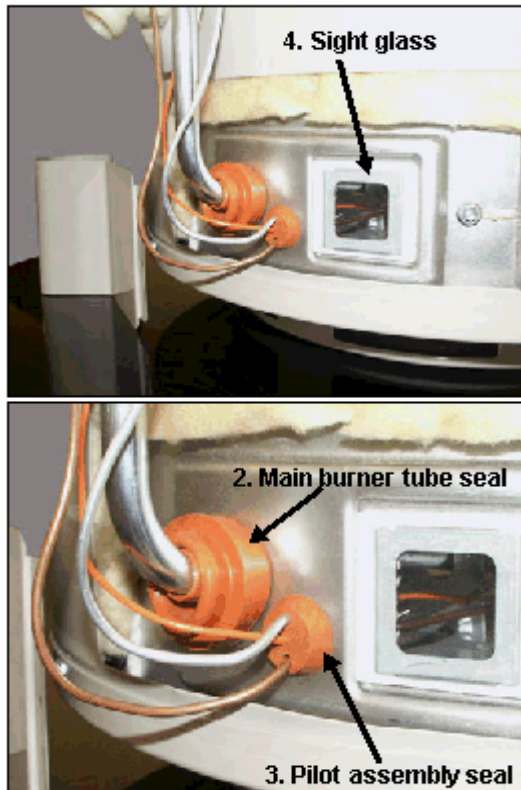

Five point inner door seal inspection:

1. Inner door gasket condition and fit.
2. Main burner tube seal condition and fit.
3. Pilot assembly seal condition and fit.
4. Sight glass, condition; present, not broken or cracked.
5. Straight routing of the thermocouple and pilot burner tube through the pilot assembly seal.

These are all critical to maintaining the C3 TECHNOLOGY integrity of the combustion chamber.

RESIDENTIAL GAS, NON POWER VENTED, WATER HEATER SERVICE HANDBOOK

PIEZO IGNITER

C3 TECHNOLOGY models will feature a Piezo igniter to light the pilot burner. The push button switch will be located on the top of the gas control valve. There will be a plug connector between the push button and the igniter wire which is part of the pilot burner assembly.

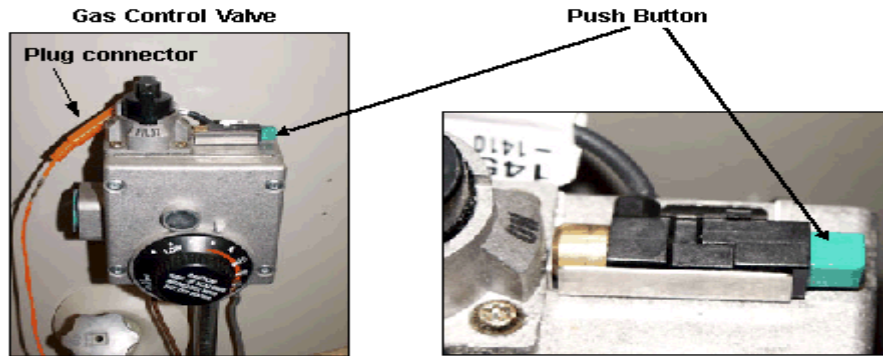

Important Service Reminder

Any time service is performed on C3 TECHNOLOGY product the Five Point Inner Door Seal Inspection outlined in the Sealed Combustion Chamber section should be performed and the LDO Screen (s) should be inspected for proper installation (arrows up) and cleaned before leaving.

Other features

All C3 TECHNOLOGY models will feature Green Choice by having a low NOx (nitrous oxide) burner which meets SCAQMD rule 1121. All C3 TECHNOLOGY models will have a brass drain valve standard.

See the “Technical Bulletins Section “ of this manual for explanations of:

- Water Hammer
- Mineral Buildup
- Aluminum Hydroxide
- Condensation
- Discolored Water
- Smelly Water
- Chlorination Process
- Lack of hot water
- Thermal Expansion
- Temperature and Pressure Relief Valve Operation

Parts Replacement – The parts on these models may change due to improvements/changes in the products. To order the current, correct replacement part for your model gas water heater, you must know the model number and (complete) serial number of your water heater. This information will be located on a black and white label, on the front of your water heater. This label will also display a star within a circle (the CSA symbol).

To order parts, contact your local State Water Heater Contractor or Distributor, phone State parts at 800-821-2018 or contact State on Web site “www.statewaterheaters.com”

RESIDENTIAL GAS, NON POWER VENTED, WATER HEATER SERVICE HANDBOOK

WHY WATER HEATER TANKS LEAK

WHAT	WHY	PREVENTION
Water Pressure	Water expands when it is heated (Thermal Expansion). Water cannot be compressed. Excessive Pressure in the tank causes failure of joints, welds or gaskets.	A Temperature and Pressure Relief Valve limits pressure to a maximum. Adding a Thermal Expansion Tank limits pressure to near supply water pressure.
Condensation)	Products of combustion contain moisture. As the combustion products cool the moisture becomes liquid – carbonic acid. The acid attacks the metal. Higher efficiency water heaters have cooler gases. Recommended water storage temperatures create cooler surfaces.	Install a water heater with capacity to minimize significant stored water temperature drop during usage. Store water at a higher temperature – install a mixing valve to reduce danger of scalding.
Contaminated Air	Bleaches, floor waxes, detergents, salt and many other household products contain chemicals which, when drawn into contact with a flame (a gas water heater uses 12 cubic feet of air for each 1000 BTU of heat generated). When these chemical vapors or dusts come into contact with a flame or electrical contact, various acids form. These acids attack the metal.	Supply the heater with clean air. “Direct Vent” water heaters use air from outside of the building for combustion.
Soft Water	Soft water minimizes mineral buildup within the tank. Minimal minerals maintain the water heater at high efficiency but may also expose interior surfaces to corrosion. Mineral buildup in some heaters prevents them leaking while greatly reducing efficiency.	A metal “Anode” rod within the tank helps to prevent internal corrosion. Maintain the self sacrificing “anode” rod by inspecting the rod annually and replacing when large “gouges” appear in its surface.

RESIDENTIAL GAS, NON POWER VENTED, WATER HEATER SERVICE HANDBOOK

WHY WATER HEATER TANKS LEAK -

Continued

WATER CONDITIONS		
WHAT	WHY	PREVENTION
"Hard" Water	"Hard" water contains minerals. As water is heated the minerals separate from the water and attach to hot surfaces within the tank. In gas water heaters, these minerals "insulate" the heat transfer surfaces conducting heat from the burner through to the water. These surfaces become hotter than if they were clean. Hotter surfaces mean more expansion and contraction of the metal as the burner cycles on and off. The metal or weld joints crack.	"Flush" the sand from the tank every 6 months. Delime the tank interior yearly. Install a water softener in hard water areas. These should be adjusted according to manufacturer's recommendations, typically for 5 grains hardness.
Water Temperature	Water stored at 160°F (72 °C) may be twice as corrosive as water stored at 140°F (60°C)	Begin with a water heater setting of 120°F (49°C) and increase only as necessary.
Usage	Each time the burner or elements cycle on and off, a small amount of metal expansion and contraction take place. As bending a piece of wire back and forth will break the wire, this expansion and contraction will eventually crack tank joints or welds.	Purchasing a proper sized tank will minimize burner or element operation when only small quantities of hot water are used.

RESIDENTIAL GAS, NON POWER VENTED, WATER HEATER SERVICE HANDBOOK

TECHNICAL BULLETIN - 11

WATER HAMMER

GENERAL	Water hammer is the destructive forces, pounding noises and vibration in a piping system when water flowing through a pipeline is stopped abruptly. When water hammer occurs, a high intensity pressure wave travels back through the piping system until it reaches a point of some relief. The shock wave will then surge back and forth between the point of relief and the point of stoppage until the destructive energy is dissipated in the piping system. The violent action accounts for “banging”, “thumping”, and/or intense vibration in the pipe line. Although noise is generally associated with the occurrence of water hammer, it can occur without audible sound or noise. Quick closure always causes some degree of shock with or without noise. The common cause of water hammer is single lever faucets (sinks/lavatories) or automatic solenoid valves (dishwashers, washing machines, etc.). The speed of the valve closure time is directly related to the intensity of the surge pressure.
EFFECTS	The damage from water hammer can manifest itself in a number of ways. The most common are: <ul style="list-style-type: none">• <i>Expanded Tank Shell</i> - This can be demonstrated by measuring the circumference at various locations along the shell. Pressures in excess of the maximum design working pressure can cause permanent deformation of the shell.• <i>Collapsed Flue Tube</i> - This will choke off the ability to vent the products of combustion causing the flame and/or combustion to spill out from the combustion chamber. Often this will occur where thinning of the flue tube walls has occurred due to contamination of the combustion air or because of excessive condensation.• <i>Inverted or Deformed Tank Heads</i> - Often this accompanies collapsed flues, but one or both heads can be deformed.
THE FIX	The only effective means of control is to install water hammer arrestors. These devices have diaphragms, which separate an air chamber from the water in the piping system. As the shock wave reaches this device, the air chamber absorbs the shock. Arrestors should be located as close as possible to the source of the shock wave.
NOTES	Since water hammer exposes the equipment to pressures in excess of its design limits, failures caused by water hammer are not eligible for warranty consideration.

RESIDENTIAL GAS, NON POWER VENTED, WATER HEATER SERVICE HANDBOOK

TECHNICAL BULLETIN - 13

MINERAL BUILD-UP

SYMPTOMS	<ul style="list-style-type: none">• Rumbling• Crackling• Popping
CAUSE	<p>With the advent of high input and larger storage tanks in both commercial and residential heaters, deliming has become a necessity of modern maintenance. Lime (CaCO_3), is the most notable factor when discussing water hardness. Lime is present in every water system to some degree across the entire United States. Since lime is inversely soluble [the more you heat, the more lime comes out], higher usage, excessive hardness, and increased heating surface can lead to a high incidence of "limed-up" heaters.</p> <p>Symptoms often include a popping of water trapped under lime deposits or the sizzling of water trapped next to elements, boiling it to steam.</p>
THE FIX	<p>Treatment of a "limed-up" heater is relatively simple. Since CaCO_3 is a base, the easiest way to dissolve it so it can be flushed from the heater is with an acid. The most commonly used is phosphoric acid at a food-grade level.</p> <p>Two common treatments available from State are Mag-Erad® and Un-Lime®. Any well-stocked plumbing supply house should have a deliming solution available.</p> <p>The directions on the product should be followed explicitly.</p>
NOTES	<p>For additional information and instructions in deliming water heaters and boilers, please refer to the following pamphlets available from State:</p> <ul style="list-style-type: none">• <i>Why? When & How: To Remove Water Scale from Tank Type Water Heaters</i>• <i>The Mag-Erad® Method of Cleaning Gas Fired Water Heaters</i>• <i>Up-N-Down™ Transfer Kit</i>• <i>All About Deliming Coil Type Water Heaters</i>

RESIDENTIAL GAS, NON POWER VENTED, WATER HEATER SERVICE HANDBOOK

TECHNICAL BULLETIN - 14

ALUMINUM HYDROXIDE

SYMPTOMS	“Crackling”, “gurgling”, or “popping” noises from new water heaters (installed less than six months).																														
CAUSE	In a few isolated parts of the United States where the water supply has a relatively high pH (8+), water conditions will react with the aluminum anode to form excessive amounts of aluminum hydroxide on the anode and in the bottom of the tank. Aluminum hydroxide looks like “jelly beads” or a green, blue or gray gel like substance in the heater drain or at faucet aerators.																														
THE FIX	This procedure should only be performed by someone with abilities equal to a licensed tradesman. Aluminum hydroxide can be removed by using one of the methods outlined.																														
	<p>If tank is new <u>with no</u> lime build-up to any degree:</p> <table border="1"> <tr><td>1</td><td>Turn off the heater.</td></tr> <tr><td>2</td><td>Remove the anode.</td></tr> <tr><td>3</td><td>Flush the tank thoroughly with water.</td></tr> <tr><td>4</td><td>Replace the aluminum anode (<i>identifiable by smooth surface on plug</i>) with magnesium anode (<i>identifiable by weld bead on plug</i>).</td></tr> </table> <p>If the tank is new <u>with</u> lime build-up to any degree:</p> <table border="1"> <tr><td>1</td><td>Turn off the heater.</td></tr> <tr><td>2</td><td>Drain the heater.</td></tr> <tr><td>3</td><td>Remove the anode.</td></tr> <tr><td>4</td><td>Add UN-LIME to the tank. 20-40 gallon models (use 3 gallons of UN-LIME) 41-65 gallon models (use 5 gallons of UN-LIME) 66-100 gallon models (use 7 gallons of UN-LIME) <i>(On electric models, be certain the lower element is immersed in solution.)</i></td></tr> <tr><td>5</td><td>Heat the UN-LIME to a temperature between 140°F to 160°F. • GAS - Heat for 7 to 10 minutes.</td></tr> <tr><td>6</td><td>Shut off the water heater.</td></tr> <tr><td>7</td><td>Allow the heated UN-LIME to stand for up to 12 minutes.</td></tr> <tr><td>8</td><td>Drain and flush the tank. Caution: UN-LIME will still be hot.</td></tr> <tr><td>9</td><td>Replace the original aluminum anode with a magnesium anode.</td></tr> <tr><td>10</td><td>Fill the system with water.</td></tr> <tr><td>11</td><td>Turn heater fuel “ON”.</td></tr> </table>	1	Turn off the heater.	2	Remove the anode.	3	Flush the tank thoroughly with water.	4	Replace the aluminum anode (<i>identifiable by smooth surface on plug</i>) with magnesium anode (<i>identifiable by weld bead on plug</i>).	1	Turn off the heater.	2	Drain the heater.	3	Remove the anode.	4	Add UN-LIME to the tank. 20-40 gallon models (use 3 gallons of UN-LIME) 41-65 gallon models (use 5 gallons of UN-LIME) 66-100 gallon models (use 7 gallons of UN-LIME) <i>(On electric models, be certain the lower element is immersed in solution.)</i>	5	Heat the UN-LIME to a temperature between 140°F to 160°F. • GAS - Heat for 7 to 10 minutes.	6	Shut off the water heater.	7	Allow the heated UN-LIME to stand for up to 12 minutes.	8	Drain and flush the tank. Caution: UN-LIME will still be hot.	9	Replace the original aluminum anode with a magnesium anode.	10	Fill the system with water.	11	Turn heater fuel “ON”.
1	Turn off the heater.																														
2	Remove the anode.																														
3	Flush the tank thoroughly with water.																														
4	Replace the aluminum anode (<i>identifiable by smooth surface on plug</i>) with magnesium anode (<i>identifiable by weld bead on plug</i>).																														
1	Turn off the heater.																														
2	Drain the heater.																														
3	Remove the anode.																														
4	Add UN-LIME to the tank. 20-40 gallon models (use 3 gallons of UN-LIME) 41-65 gallon models (use 5 gallons of UN-LIME) 66-100 gallon models (use 7 gallons of UN-LIME) <i>(On electric models, be certain the lower element is immersed in solution.)</i>																														
5	Heat the UN-LIME to a temperature between 140°F to 160°F. • GAS - Heat for 7 to 10 minutes.																														
6	Shut off the water heater.																														
7	Allow the heated UN-LIME to stand for up to 12 minutes.																														
8	Drain and flush the tank. Caution: UN-LIME will still be hot.																														
9	Replace the original aluminum anode with a magnesium anode.																														
10	Fill the system with water.																														
11	Turn heater fuel “ON”.																														
NOTE	Since aluminum hydroxide is a product of a chemical reaction dependent on the water condition, any treatment is not considered warranty related.																														

RESIDENTIAL GAS, NON POWER VENTED, WATER HEATER SERVICE HANDBOOK

TECHNICAL BULLETIN - 21

DISCOLORED WATER

SYMPTOMS	Rusty, brown, black, or yellow water appearing in the hot water.
CAUSE	<p>Complaints of discolored water are commonly blamed on water heaters and storage tanks, but in fact, it is a rare occurrence for today's high quality glass lined tanks to have a lining failure significant enough to allow water to contact enough bare metal to discolor the contents of even a small tank.</p> <p>The most common cause of "rusty" water is a non-toxic iron reducing bacteria, scientifically termed Crenothrix, Leptothrix, and Gallionella. Iron bacteria is commonly found in soil, water wells, water treatment plants and water distribution piping systems where soluble iron exceeds 0.2 ppm, higher levels make conditions even more favorable. Soluble iron in the water provides food for the bacteria. Rusty discolored water is the end result of the bacteria feeding process. Water heaters and storage tanks usually require new anode rods as presence of iron bacteria contributes to premature anode failure.</p> <p>The requirements for the bacteria to thrive are:</p> <ul style="list-style-type: none">• Elevated level of iron and manganese in the water• Water with little or no dissolved oxygen• Temperatures below 138°F <p>Items that can increase the potential for this bacteria are:</p> <ul style="list-style-type: none">• Water softeners• Well water• Long periods of no water movement
TREATMENT	The simplest treatment available is shock-chlorination of the system. This is a surface treatment, and often requires repeated trials in heavily infected systems. The chlorination of a system requires that you follow each step explicitly to avoid an un-treated portion of the piping system from reinfesting another part. See Bulletin 23 for the chlorination procedure.
NOTE	Since rusty water is caused by a bacteria presence and is not caused by the water heater, any treatment would not be considered warranty related.

RESIDENTIAL GAS, NON POWER VENTED, WATER HEATER SERVICE HANDBOOK

TECHNICAL BULLETIN - 22

SMELLY WATER

CAUSE	<p>The most common cause of “smelly water” is a non-toxic sulfate reducing bacteria, scientifically termed <i>Divibrio Sulfurcans</i>. This bacterium often enters the water system through construction or a break in ground piping. The bacteria create the energy it needs to survive by converting sulfate (SO₄) to hydrogen sulfide (H₂S) gas you smell in the water.</p> <p>Hydrogen sulfide gas is distinctive because of its rotten egg-like stench. Its presence can severely affect the taste as well as the odor of the water. Occasionally these bacteria can be accompanied by black deposits, the result of pipe and fitting corrosion. In extremely high concentrations, hydrogen sulfide gas can be toxic though the gas is detectable long before harmful levels are reached.</p> <p>The requirements for the bacteria to thrive are: a) an elevated level of sulfur in the water, b) activated hydrogen from cathodic reactions within the tank, c) water with little or no dissolved oxygen, d) and temperatures below 138°F.</p> <p>Items that can increase the potential for these bacteria are: a) water softeners, b) well water, c) and long periods of no water movement.</p> <p>Other factors that may contribute to smelly water:</p> <ul style="list-style-type: none">• Chlorides of Magnesium and Calcium leave a bitter taste.• Chloride of Sodium produces a salty taste.• Sulfates (50 ppm) give a medicinal taste.• Carbon Dioxide in low pH water gives fizzy water.• Iron and tannic waters also give a bad taste and odor.
TREATMENT	<p>The simplest treatment available is the shock-chlorination of the system. This is a surface treatment, and often requires repeated trials in heavily infected systems. The chlorination of a system requires that you follow each step explicitly to avoid an un-treated portion of the piping system from reinfesting another part. See Bulletin 23 for the chlorination procedure. Longer lasting solutions include chlorination or aeration of the water supply.</p>
NOTE	<p>Since smelly water is caused by a bacteria presence and is not caused by the water heater, any treatment would not be considered warranty related.</p>

RESIDENTIAL GAS, NON POWER VENTED, WATER HEATER SERVICE HANDBOOK

TECHNICAL BULLETIN - 23

CHLORINATION PROCEDURE

CAUSE	The chlorination procedure is used to eliminate various bacteria that accumulate and grow in water heaters. These bacteria often cause odorous or discolored water conditions.
--------------	--------------------------------------------------------------------------------------------------------------------------------------------------------------------------------

PROCEDURE	Please read the steps of the chlorination procedure prior to beginning. If you feel uncomfortable performing any of these steps, contact a service person to perform this procedure for you.
<i>STEP 1</i>	Turn off the gas supply to the tank.
<i>STEP 2</i>	Turn off the cold water supply valve to the tank.
<i>STEP 3</i>	Open a nearby hot water faucet to relieve the vacuum.
<i>STEP 4</i>	Drain all the water from the tank (a water-hose may be needed).
<i>STEP 5</i>	Remove the anode rod(s), and close the drain valve.
<i>STEP 6</i>	Using a funnel in the anode opening add one gallon of household chlorine bleach (e.g. Clorox or Purex) for every 25 gallons of tank capacity.
<i>STEP 7</i>	Reinstall anode rod(s) after inspecting and replacing as needed.
<i>STEP 8</i>	Open cold water supply valve and refill the system. Then draw the water to <u>every</u> hot water fixture, until the smell of chlorine is detected. Operate dish and clothes washers until a noticeable amount of the chlorine is detected as well. All hot water lines must receive treatment.
<i>STEP 9</i>	Leave the chlorine solution undisturbed for one hour or more.
<i>STEP 10</i>	After the contact time has elapsed, drain the tank according to steps #2, #3, & #4.
<i>STEP 11</i>	Close the drain valve and refill the tank. Allow the tank to sit for 15 minutes. Repeat steps #2, #3, and #4. Continue to flush the tank if the water is discolored or contains a chlorine odor.
<i>STEP 12</i>	Close the drain valve and refill the tank. Flush <u>all</u> chlorine from the piping by opening every hot water outlet/ appliance.
<i>STEP 13</i>	Return hot water heating system to service by following the recommended start-up procedure posted on the unit or in the manual.

RESIDENTIAL GAS, NON POWER VENTED, WATER HEATER SERVICE HANDBOOK

TECHNICAL BULLETIN - 35

NOT ENOUGH HOT WATER - GAS

CAUSE	Not enough hot water complaints are becoming more frequent in the water heater industry. This increase was triggered when changes required by our regulatory agencies were implemented. For example, heaters are now factory preset at a lower temperature and inlet tubes have been shortened. While lower temperatures settings reduce the burn rate, and shorter dip tubes guard against stacking, both affect the amount of hot water a water heater can supply. The following test will help determine if a water heater is supplying the intended amount of hot water and will help pinpoint any problems that exist.
--------------	-----------------------------------------------------------------------------------------------------------------------------------------------------------------------------------------------------------------------------------------------------------------------------------------------------------------------------------------------------------------------------------------------------------------------------------------------------------------------------------------------------------------------------------------------------------------------------------------------------------------------------

TEST	Please read all the steps of the test prior to beginning. If you feel uncomfortable performing any of these steps, contact a service person to conduct this test for you.												
<i>STEP 1</i>	At the faucet nearest to the water heater, time (in seconds) how long it takes to fill a 1 gallon bucket (flow rate). $\text{Gallon per minute (gpm)} = 60 \text{ seconds} / \text{seconds to fill a 1 gallon bucket}$ <i>If the bucket fills in:</i> 10 sec = 6 gpm 12 sec = 5 gpm 15 sec = 4 gpm 20 sec = 3 gpm 24 sec = 2.5 gpm												
<i>STEP 2</i>	Turn thermostat dial on the water heater so the arrow points to "A" position.												
<i>STEP 3</i>	Run about 15 gallons of hot water from the nearest faucet. Shut water off.												
<i>STEP 4</i>	Water heater should complete heating 15 gallons in approximately 20-35 minutes.												
<i>STEP 5</i>	At a nearby faucet using a candy thermometer, measure the hot water temperature.												
<i>STEP 6</i>	The temperature should fall between 120°F to 140°F.												
<i>STEP 7</i>	Continue running the hot water until 60% of the tank capacity is depleted: <table style="margin-left: auto; margin-right: auto;"> <thead> <tr> <th style="text-align: center;">CAPACITY</th> <th style="text-align: center;">DEplete</th> </tr> </thead> <tbody> <tr> <td style="text-align: center;">30 gallons</td> <td style="text-align: center;">18 gallons</td> </tr> <tr> <td style="text-align: center;">40 gallons</td> <td style="text-align: center;">24 gallons</td> </tr> <tr> <td style="text-align: center;">50 gallons</td> <td style="text-align: center;">30 gallons</td> </tr> <tr> <td style="text-align: center;">75 gallons</td> <td style="text-align: center;">45 gallons</td> </tr> <tr> <td style="text-align: center;">100 gallons</td> <td style="text-align: center;">60 gallons</td> </tr> </tbody> </table>	CAPACITY	DEplete	30 gallons	18 gallons	40 gallons	24 gallons	50 gallons	30 gallons	75 gallons	45 gallons	100 gallons	60 gallons
CAPACITY	DEplete												
30 gallons	18 gallons												
40 gallons	24 gallons												
50 gallons	30 gallons												
75 gallons	45 gallons												
100 gallons	60 gallons												
<i>STEP 8</i>	At the same faucet using a candy thermometer, measure the water temperature.												
<i>STEP 9</i>	The temperature should be about 30°F below the temperature in step 6.												

THE FIX	Step 6 - if the temperature was not within range, check the thermostat. Step 9 - if more than 30 °F was lost, check the dip tube.
----------------	--------------------------------------------------------------------------------------------------------------------------------------

RESIDENTIAL GAS, NON POWER VENTED, WATER HEATER SERVICE HANDBOOK

TECHNICAL BULLETIN - 45

THERMAL EXPANSION

SYMPTOMS	<ul style="list-style-type: none">• Effects are only noticeable after hot water use followed by periods of no water use.• Relief valve drips during any recovery cycle when no hot or cold water is used.• Hot water pipes creak while heater is recovering and all valves are closed.• Tanks or other components of the water supply system fail prematurely.• A metallic creaking noise might actually be heard in the location of the heater as the pressure is relieved and the stretched tank returns to a natural shape.• Faucets drips during any recovery cycle when no hot or cold water is used. Water surges when a valve is first open and then pressure drops.
CAUSE	<p>The water in a water heating system expands when it is heated and has a greater volume. Since water will not compress (like air), system designers must include provisions for thermal expansion. (Water in a closed tank at 50 psi, when heated just 10 degrees, will reach a pressure of 250 psi).</p> <p>Many water supply systems have check valves at the water meter to prevent any possible contamination of the public water supply by the accidental back-flow of contaminated water into the supply mains. These check valves are often required by code, and some cities are even installing the check valves. They serve a useful purpose. Do not remove them!</p> <p>The use of pressure reducing valves (PRV) is another cause. PRVs are designed to conserve water and prolong fixture life. Many PRVs also act as very effective check valves. Again, do not remove them!</p> Water softeners in the system may also act as back-flow preventers.
TEST	<p>Follow these easy steps to diagnose thermal expansion:</p> <ul style="list-style-type: none">• Turn the heater thermostat all the way down, and install a water pressure gauge with dead hand (part #4798) on the drain valve. Open the drain valve, so the gauge reads system pressure.• Open a hot water tap and allow 15% to 20% of the tanks volume to run out. Shut off the drain valve and make sure that no other fixture in the system, hot or cold, is open. Make sure that outside fixtures, if they are on the same system, are turned off too. Any water leaks or use will make the test meaningless.• Check the water pressure gauge, and turn the pointer so it lines up with the pressure indicating needle. Turn the thermostat back up to its normal position, so the heater cycles on. Watch the pressure gauge.• If the system is closed, the pressure will start to climb steadily and rapidly. A small amount of thermal expansion control may be built into the system because of trapped air pockets or a water hammer arrestor. In that case the pressure will increase slightly, hold steady for a short time and then rapidly increase. The temperature and pressure relief valve (T&P) or PRV should open and release water once the pressure reaches the maximum setting on the valve. The valve will close once the pressure falls below the pressure setting of the valve.

RESIDENTIAL GAS, NON POWER VENTED, WATER HEATER SERVICE HANDBOOK

THE FIX

The ideal fix involves the use of a pressure reducing valve if supply pressures are above 60 to 70 psi, and a properly sized expansion tank. The PRV reduces supply pressures to 40 to 60 psi allowing an economically priced and sized expansion tank to be used. The PRV also offers the benefit of saving water and prolonging the life of water flow valves. The PRV is not required if the system already has one or if high supply pressures are desired.

The PRV is installed between the check valve and the water heating system. The expansion tank is installed between the PRV and the water heating system. Follow the manufacturers' instructions for installing the expansion tank.

Run the thermal expansion check again. The pressure should increase only slightly then hold steady throughout the recovery cycle. The expanded water is flowing back from the heater and into the pressurized storage bladder of the expansion tank. Air pressure will force this water out of the expansion tank into the supply once usage resumes.

DO NOT DEPEND ON THE T&P VALVE TO HANDLE THERMAL EXPANSION! The T&P valve, according to the makers of those valves, was designed as an emergency relief device only. The T&P could be subject to reduced effectiveness or failure.

FIGURE

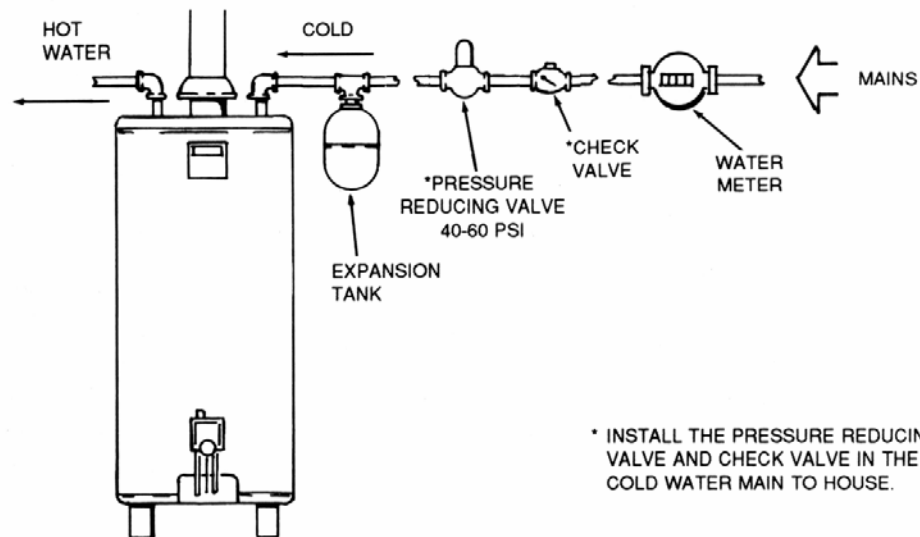

WARNING

Thermal expansion of water, if not compensated for in system design, will lead to the early failure of components. These failures are not covered by the manufacturer's warranty, so it is extremely important that everyone be aware of the causes, symptoms and solutions to thermal expansion in a closed water heating system.

RESIDENTIAL GAS, NON POWER VENTED, WATER HEATER SERVICE HANDBOOK

TECHNICAL BULLETIN - 52

LEAKING TEMPERATURE AND PRESSURE RELIEF VALVE

SYMPTOMS	<ul style="list-style-type: none"> • Water seeping around the relief valve tank connection • Leakage at the threaded portion of the relief valve connection • Intermittent weeping and/or dribbling from the relief valve • Large volume of hot water sporadically discharged from the relief valve
GENERAL	<p>The temperature and pressure relief valve (T & P) is a safety device limiting temperature and pressure levels in a water heater. Each T & P has both a temperature and pressure rating.</p> <p>Normally, the temperature and pressure relief valve will have a temperature rating for 210°F. A probe (part of the relief valve) extends into the tank measuring the stored water temperature. This probe must be within the top six inches of the water heater. However, if the water heater's thermostat malfunctions, higher than normal water temperatures could be produced. Once the probe senses a temperature exceeding its temperature rating, the relief valve will open to full capacity releasing "very hot" water until the temperature is below its reset temperature.</p> <p>The pressure rating on the relief valve should be the same or less than the certified working pressure of the tank (generally 150 psi) and be below the lowest pressure rating of any system components. It is not acceptable to install a relief valve that exceeds the maximum working pressure of the water heater. Once the pressure in the tank reaches the valve's pressure rating, it will slightly open relieving the pressure. Relieving of pressure can be noted as "dribbling" or "weeping" water from the relief valve.</p> <p>If an incorrectly sized temperature and pressure relief valve is installed, the warranty will be void.</p>
THE FIX	<ul style="list-style-type: none"> • <u>Seeping at the spud of the water heater</u> - Spuds are welded to the tank and are not repairable. The heater should be replaced. • <u>Leakage at the threaded relief valve connection</u> - Remove relief valve and reseal connection. • <u>Intermittent weeping and/or dribbling at the relief valve</u> - The relief valve relieves water slowly when actuating on pressure. A closed system can cause pressure to increase in the system. This condition is called thermal expansion. For additional information regarding thermal expansion please see Bulletin 45. • <u>Large volume of hot water sporadically discharged from the relief valve</u> - The relief valve relieves water quickly when actuating on temperature. The only cause of this problem is a malfunctioning thermostat.

To order additional copies of this Service Handbook and to view other service and presentation literature and CDs that are available from State Water Heaters:

Telephone 1-800-821-2017, Fax number 800-644-9306 or visit our web site at www.statewaterheaters.com

For additional information or assistance in servicing you're State water heater, visit our web site or telephone the Technical Information Department at 1-800-365-0024

This Service Handbook was prepared by the Technical Training Department, Ashland City, TN.